

Product Preview

uT83RNUCOS

**DUAL INTERFACE SMARTCARD MCU WITH
UCOS**

Revision 0.2

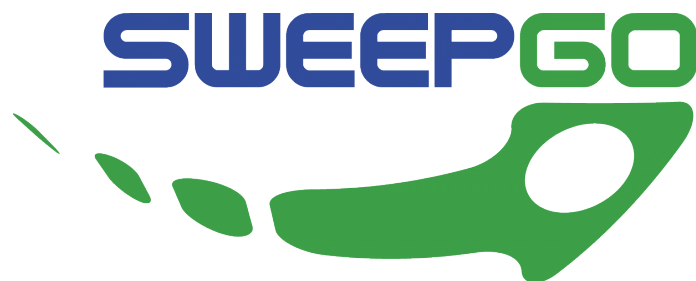

Copyright © 2013 Microtech Innovation Limited
All Rights Reserved.

Any usage or redistribution of this document without the express written consent of Microtech Innovation Limited is strictly prohibited.

Microtech Innovation Limited reserves the right to make any modifications or updates to this product or any component thereof for any reason whatsoever without further notice to anyone. Microtech Innovation Limited does not assume any liability arising out of the application or use of this product nor any component thereof; neither does it convey nor license under its patent rights or copyrights nor the patent rights or copyrights of others all or any portion of this product. Microtech Innovation Limited products are not designed, intended, or authorized for use as components in systems intended for surgical implant into the body, other applications intended to support or sustain life, or for any other application in which the failure of the Microtech Innovation Limited product could create a situation where personal injury or death may occur. Should Buyer purchase or use Microtech Innovation Limited products for such unintended or unauthorized application, Buyer shall indemnify and hold Microtech Innovation Limited and its officers, employees, subsidiaries, affiliates, and distributors harmless against all claims, costs, damages, and expenses, and reasonable attorney fees arising out of, directly or indirectly, any claim of personal injury or death associated with such unintended or unauthorized use, even if such claims alleges Microtech Innovation Limited was negligent regarding the design or manufacture of the part.

1 INTRODUCTION

The uT83RNUCOS is a member of the Microtech Dual Interface Smart Card product family specifically designed for contact and contactless smart card applications which requires more flexibility to interface with different built-up infrastructures. It complies with ISO7816 and ISO14443 Type A and B standards. The RF front-end can support data rate up to 106Kbps.

uT83RNUCOS is targeting for high security applications such as electronic purse, automatic fare collection, multi-function ID and security access.

1.1 FEATURES

- Non-volatile Memory
 - 16K-bytes or 64KB high speed user data NVM
 - Over 10 years data retention
 - Over 100K write/erase cycles
- File System
 - Flexible and user configurable file system
 - Supports up to 256 files in multiple directory level
 - Support four different file types
 - Supports up to 255 records for each record structure file
- Contactless
 - Operating Frequency: 13.56MHz
 - Support ISO14443 Type A and B
 - Support 106 in both Type A and B mode
 - Contact / contactless auto-detect
- Security
 - Full hardware triple Data Encryption Standard (DES) module can support single DES and triple DES operation
 - 11-Byte unique serial number for each chip
 - Support both internal and external authentication
 - Support secure messaging with MAC
 - File access is controlled using triple DES key authentication and PIN verification

2 GENERAL OVERVIEW

The uT83RNUCOS is a member of the Dual Interface Smart Card product family specifically designed for contact and contactless smart card applications. It features ISO 14443 (contactless) and ISO 7816 (contact) communication interfaces.

uT83RNUCOS can be used as a contactless only card or dual interface card. The pin assignment of this chip is shown in figure 1. AT0 and AT1 is the bonding pad for external coil consisting of a few turns embedded in a standard ISO smart card. When the card is put over the antenna of a ISO 14443 card reader, it will be powered up by the RF signal and ready to communicate with the card reader according to the ISO 14443 Type A or B protocol. For details about the ISO 14443 type A and B protocol, please refer to the ISO 14443 standard.

uT83RNUCOS comes in one of the two different packages:

- Unsawn wafer
- XOA2 contactless module
- Combi module
- White contactless card
- White combi card

Contact mode pins:

VCC Power pin
RST Reset pin
CTCLK Contact clock pin
VSS Ground pin
PA0 I/O pin

Contactless mode pins:

AT0 RF coil connect pin
AT1 RF coil connect pin

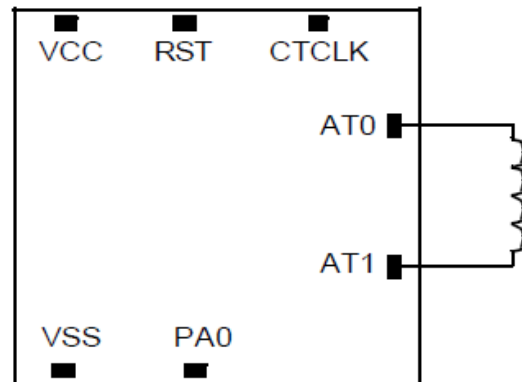

Figure 1: uT83RNUCOS Contact / Contactless Pins Assignment

3 GENERAL DESCRIPTION

- Supports up to 256 files in multiple directory level.
- Supports file structures of
 - Fixed and variable length linear record,
 - Fixed length cyclic record and
 - Transparent
- Supports full set of functions in Read and Update Record commands including record searching using Seek command.
- File access is controlled by READ, UPDATE and SELECT security attributes using triple DES key authentication and PIN verification.
- Supports up to 255 records for each record structure file.
- There are 7 global double length DES keys (1 Issuer Key and 6 application keys) and 1 global PIN. For each DF, there are up to 127 local DES keys and 1 local PIN. Each DES key can be diversified before used.
- Supports secure messaging with MAC.
- Supports electronic purse with Debit and Credit commands.
- Supports counter with Increase and Decrease commands.
- Supports PPS, T=0 and T=1 protocols including chaining for speed up to 115200bps at 3.58MHz input clock.
- Support ISO 14443 Type A or B protocols up to 106kbps.

Ordering Part Number	RF Protocol	Max. number of files	File area size (byte)	Max. record size (byte) without MAC	Max. record size (byte) with MAC
uT00035	ISO 14443 A	256	16256	255	240
uT00036	ISO 14443 B	256	16256	255	240
uT00051	ISO 14443 A	256	62848	255	240

Figure 2: Ordering Information and File System Maximum Parameters